

V O L V O



Volvo Excavators 16.2-17.5 t 115 kW

EWR150

Volvo Construction Equipment

EWRI50

The EWR150 is the ultimate 15-tonne short swing wheel excavator. Now with more power, reach, lifting capacity and manoeuvrability, this is the perfect partner for productivity in urban and confined workspaces.



Best in class short swing performance

Introducing the best 15-tonne short swing radius wheel excavator on the market. The EWR150 is packed with new and improved features to take its class-leading performance to new heights – including 10% more engine power, increased reach, increased lifting capacity and a reduction in front swing radius by more than 0.5 m. The result is more productivity, efficiency, manoeuvrability and machine performance than ever before, making the EWR150 the perfect choice when working in urban environments and other confined spaces.



Best in class performance

- Increased lifting capacity over front of the machine
- Newly designed longer 2-piece boom for increased reach
- Shortest rear swing radius in its class
- Front swing radius reduced by more than 0.5 m
- 10% more engine power (new 115 kW engine)
- 10% more swing torque
- Optional 4-wheel steering



Efficient performance

- Advanced engine technology and intelligent hydraulics
- Auto-idle and automatic engine shutdown
- Advanced electro-hydraulic load sensing system



The ultimate operator environment

- New operator interface with all machine information displayed in single 12.8" touchscreen
- Superior visibility
- Low noise levels
- Outstanding storage options, wireless phone charging, USB connections
- Automatic in-cab lights
- Range of options including air compressor for cleaning, and right-hand sunshade
- Choice of 3 ergonomic joysticks
- Customisable settings
- Different seat suppliers with 3-point seatbelt as option



Versatility

- Choice of 2.0 m, 2.4 m and 2.6 m arm lengths
- New optional 2.75 m wide axle
- Wide range of Volvo Attachments
- X1 and X3 auxiliary lines have been increased in size for less pressure losses
- X3 flow has also been increased from 70 to 120 litres/minute
- A third auxiliary line (X4) is available as an option



Designed for uptime

- Robust frame and high-quality components
- Grouped greasing points
- Ground-level access to essential service areas
- Optional hydraulic oil quick fill
- Optional extra fuel tank in the undercarriage
- Lockout/Tagout
- CareTrack telematics



Optimized for safety

- Comfort Cabin Stairs (Volvo patented)
- Optional Volvo Smart View with HD360-degree real-time view
- LED work lights
- Improved, newly designed anchor points for transportation

Comfort cabin stairs

The Volvo patented electronically retractable ladder swings down from a recess in the side of the machine to provide safe and easy entry and exit to cab. For additional safety, the machine cannot swing or move while the ladder is in the down position.

Lift more, reach further

The already renowned performance of the EWR150 is taken to a new level thanks to an increased lifting capacity over the front of the machine, made possible by the larger diameter of the lift cylinders. Combine this with a newly designed longer 2-piece boom which delivers an increased reach, and the EWR150 is ready to deliver top results.

Industry renowned fuel efficiency

The Volvo EWR150 is built for efficiency, featuring advanced engine technology and intelligent hydraulics that reduce fuel consumption while maintaining top performance. Features including auto-idle and automatic engine shutdown, and efficient power modes combine to further enhance efficiency in every task. An optional extra fuel tank in the undercarriage supports a longer working range between refills for increased uptime.

The ultimate operator environment

Every detail of the Volvo EWR150 cab has been redesigned with operator comfort and convenience in mind, with superior visibility, low noise levels and ergonomic controls ensuring operators stay comfortable and focused throughout the workday. Combine this with easy-to-use joystick controls, outstanding storage options, wireless phone charging, USB connections, automatic in-cab lights and a range of options such as an air compressor for cleaning, and right-hand sunshade. This is truly an operator environment like no other.





Volvo EWR150 in detail

Engine

EU Stage V / EPA Tier 4f with Volvo Advanced combustion technology (V-ACT).
Volvo machines are equipped with in-line turbo charged diesel engine with high pressure unit injector system. The engine features a externally cooled exhaust gas re-circulation (E-EGR) , a Diesel Particulate Filter (DPF) and a Selective Catalytic Reduction(SCR) with AdBlue.

Engine	Volvo	Volvo D4J
Max. power at	r/min	2 000
Net (ISO9249/SAEJ1349)	kW	112
	hp	152
Gross (ISO 14396/SAE J1995)	kW	115
	hp	156
Max. torque	Nm	618
at engine speed	r/min	1 500
No. of cylinders		4
Displacement	l	4.04
Bore	mm	101
Stroke	mm	126

Electrical system

High-capacity electrical system that is well protected. Waterproof double-lock harness plugs are used to secure corrosion-free connections. The main relays and solenoid valves are shielded to prevent damage. The master switch is standard.

Voltage	V	24
Batteries	V	2 x 12
Battery capacity	Ah	2 x 100
Alternator	V/Ah	24 / 130
Alternator rating	W	3 360

Undercarriage and structures

Drivetrain: A variable axle piston motor in combination with a power shift gearbox supplies 3 speeds. The gearbox distributes than the energy via propeller shafts to the axles.

2 different undercarriages : a) Welded undercarriage with radial blade front and outriggers rears. b) Bolted undercarriage with parallel blade and outriggers in different combinations

Wheels: Alternative single and twin wheels available.

Front axle: Robust excavator axle with automatic or operator controlled front axle oscillation lock.

Oscillation	± °	9
with mudguards	± °	6
Twin wheels	type	10 - 20
Tractive force (net)	kN	111
Travel speed, on road	km/h	20 / 30 / 35
Travel speed, off road	km/h	8.5
Travel speed, creep	km/h	2
Min. turning radius	m	6.4 with 2WS/ 4.5 with 4WS*

*with Mitas 10" twin tyres, depending on tyres and lower frame configuration

Cab

Redesigned Volvo Cab with operator protective structure,with new seats and new large storage space below the consoles and new interior lighting . Integrated wireless phone charger and extra Cooling box behind the operator.

Audio system with remote control and Bluetooth system for hands free phoning. Independently adjustable joystick consoles with 2 type of arm rests fixed to the console .The unique 12.8" touchscreen is attached to the righthand console for optimum view and takes away a lot of switches from the consoles . The cab is supported on hydraulic dampening mounts to reduce shock and vibration levels.

Excellent all-round visibility provided by maximized cab class, transparent roof hatch, 2-piece sliding door window . The liftable front windshield can easily be stored in the inside roof space and clipped in position. The removable lower front glass can be stored in the side door pocket.

Sound Level

Sound pressure level in cab according to ISO 6396

L _{pA}	dB	71
-----------------	----	----

External sound level according to ISO 6395 and EU Noise Directive 2000/14/EC

L _{WA}	dB	100
-----------------	----	-----

Hydraulic System

The new electro-hydraulic system with closed-centre load sensing Main Control Valve with pressure compensated valves and the electronic controlled pump provide superior controllability and new adjustment possibilities like speed and priority settings. Load independence of movements. Flow sharing feature, combined with a high flow pump (power regulation). The system gives superior manoeuvrability and fast movements, for optimal working result and economy.

The following working modes are included in the system:

Parking mode (P): Parking position for optimal safety.

Travel mode (T): Engine speed is controlled by travel pedal stroke for low fuel consumption and noise.

Working mode (W): Full working flow with adjustable engine rpm for normal working and best speed utilisation.

Power Boost: All digging and lifting forces are increased.

Main pump (type low noise axial piston pump)

Max. flow	l/min	260
-----------	-------	-----

Brake + steering pump (type low noise gear pump)

Max. flow	l/min	41
-----------	-------	----

Attachment circuit

Max. flow	l/min	220
-----------	-------	-----

Max. pressure

Implement	MPa	34 / 37.5
Travel system	MPa	37.5
Pilot system	MPa	3.5

Brake system

Service brakes: servo-hydraulically manoeuvred self-adjusting wet multidiscs with two separate brake circuits.

Parking brake: negative wet disc in gear housing, spring applied and pressure released.

Digging brake: service brake with mechanical lock system.

Security system: The 2-circuit travel brakes are supplied with two accumulators in the event of failure in the service brake system.

Swing system

The superstructure is slewed by the means of a axial piston motor with reduction gear. Automatic slew holding brake and anti-rebound valve are standard.

Max. slew speed	r/min	8
Max. slew torque	kNm	38

Total Machine Weights

Machine with 4.92 m 2-piece boom, 2.4 m dipper arm, quickcoupler S60, Mitas 10" twin tyres, 410 kg /580 l bucket.

With welded radial dozer blade front and outriggers rear	kg	16 700
--	----	--------

With bolted dozer blade front and outriggers rear	kg	17 300
---	----	--------

With bolted dozer blade rear only	kg	16 200
-----------------------------------	----	--------

Service Refill

Fuel tank	l	220
DEF/AdBlue® tank	l	25
Hydraulic system, total	l	230
Hydraulic tank	l	96
Engine oil	l	16
Engine coolant	l	16
Transmission	l	2.5
Axle differential:		
Front axle	l	9.5
Rear axle	l	12.5
Final drive	l	4 x 2.5



Specifications

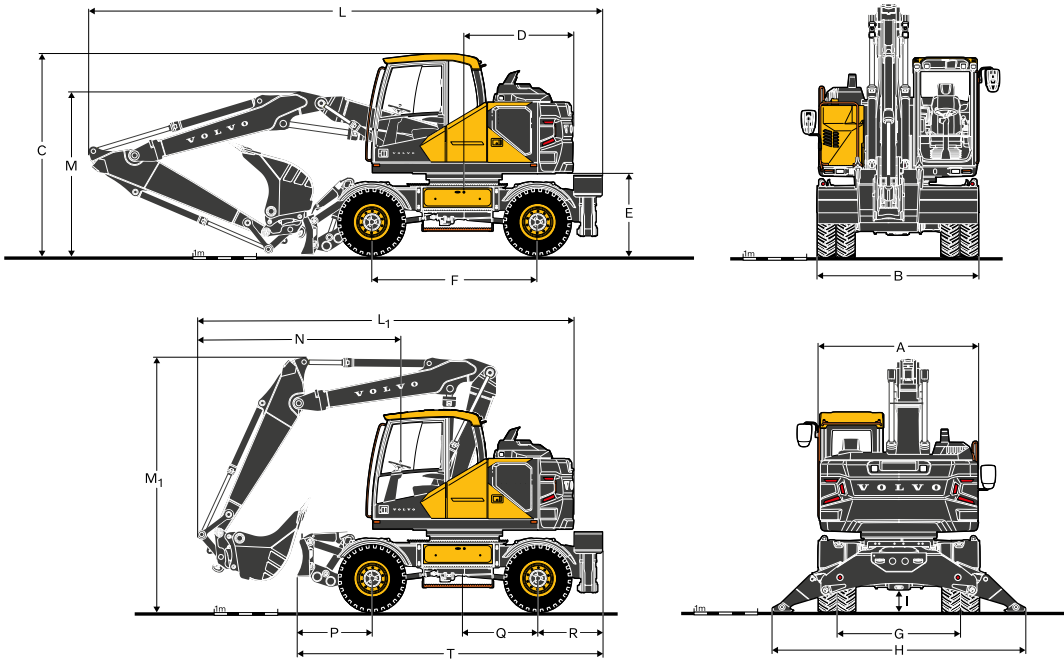

DIMENSIONS		EWR150F			
Description	Unit	2-piece boom			
	m	4.9			
A	Overall width of superstructure	mm	2 520		
B	Overall width	mm	2 550		
C	Overall height of cab	mm	3 150		
D	Tail slew radius	mm	1 720		
E	Counterweight clearance	mm	1 270		
F	Wheel base	mm	2 600		
G	Tread	mm	1 940		
H	Outrigger width (front or rear)	mm	3 980		
I	Min. ground clearance	mm	350		
Description	Unit	2-piece boom			
	m	4.9			
Description	Unit	Arm			
		m	2.0	2.4	2.6
L	Overall length	mm	8 060	8 080	8 050
M	Overall height of boom	mm	2 400	2 550	2 830
L ₁	Overall length	mm	6 260	6 430	6 530
M ₁	Overall height of boom	mm	4 000	4 000	4 000
N	Front overhang	mm	3 030	3 200	3 300

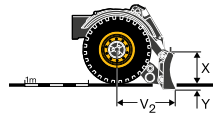
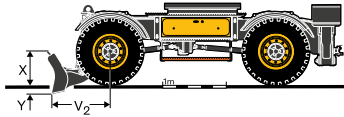
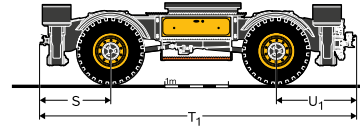
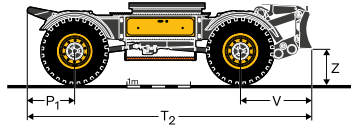
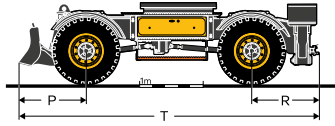

DIMENSIONS

Description	Unit	Undercarriage dimensions radial Blade	In case of parralle blade
P	mm	1 080	1 180
P ₁	mm	-	750
Q	mm	1 150	1 150
R	mm	1 040	1 060
S	mm	-	1 110
U	mm	-	1 060
U ₁	mm	-	1 250
T ₁	mm	-	4 970
T	mm	4 720	4 840
T ₂	mm	-	4 470
V	mm	-	1 120
V ₂	mm	-	920
X	mm	-	460
Y	mm	160	140
Z	mm	260	530

Specifications

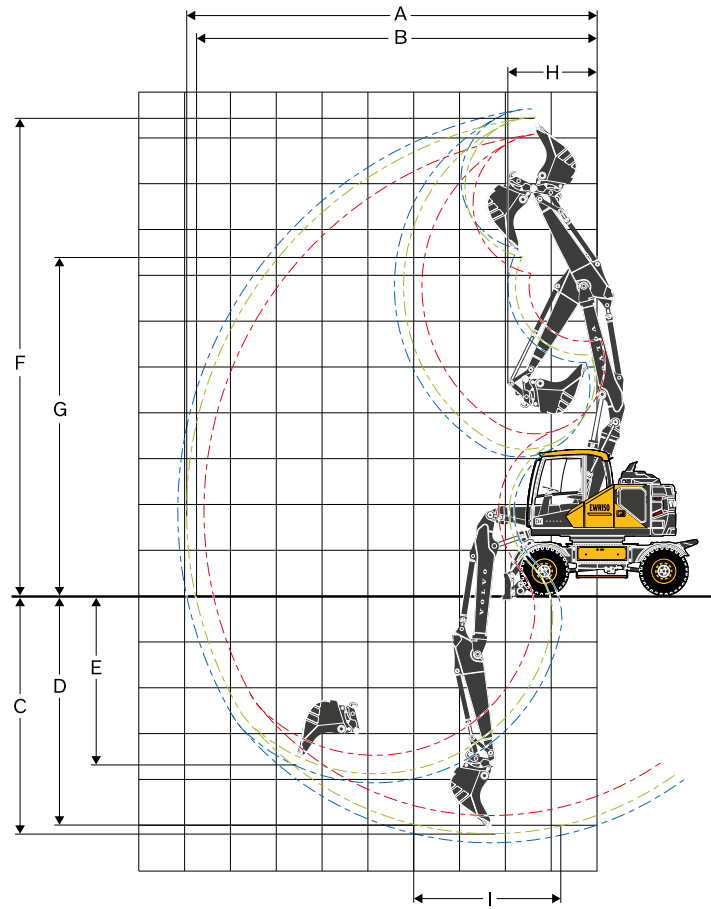

WORKING RANGES WITH DIRECT FIT BUCKET

		EWR150F 4.9 m 2-piece boom			
		Unit	Arm		
		m	2.0	2.4	2.6
A	Max. digging reach	mm	8 580	8 960	9 120
B	Max. digging reach on ground	mm	8 390	8 780	8 970
C	Max. digging depth	mm	4 840	5 230	5 430
D	Max. digging depth (l = 2 440 mm level)	mm	4 720	5 130	5 330
E	Max. vertical wall digging depth	mm	3 750	4 140	4 340
F	Max. cutting height	mm	10 050	10 410	10 590
G	Max. dumping height	mm	7 000	7 360	7 540
H	Min. front slew radius	mm	1 710	1 930	2 040

DIGGING FORCES WITH DIRECT FIT BUCKET

Breakout force (bucket)	(ISO)	kN	108.5*	108.5*	108.5*
Tearout force	(ISO)	kN	76*	67*	63*

Max. recommended sizes for direct fit buckets

GP-Bucket (1.8 t/m ³)	l	730	670	640
-----------------------------------	---	-----	-----	-----

Max. recommended sizes for quick fit buckets

S6/S60 QF GP-Bucket (1.8 t/m ³)	l	670	610	580
---	---	-----	-----	-----

Note: 1. Bucket size based on SAE-J296, heaped material with a 1:1 angle of repose. | 2. "Max permitted sizes" are for reference only and are not necessarily available from the factory.

*with Power boost

LIFTING CAPACITY EWR150F - Welded undercarriage

At the arm end, without bucket and quick fit. Unit: 1 000 kg.

For lifting capacity including bucket/quick fit, simply subtract actual weight of those parts from the following values.

	Lifting point	Reach from machine centre (u = support up/d = support down)																						
		3.0 m					4.5 m					6.0 m				7.0 m				Max.				
		Across UC		Along UC			Across UC		Along UC			Across UC		Along UC		Across UC		Along UC		Across UC		Along UC	Max.	
		m	u	d	u	d	u	d	u	d	u	d	u	d	u	d	u	d	u	d	u	d	m	
2P Boom: 4.92 m Arm: 2.0 m Radial blade front/ outrigger rear	7.5	7.2*	7.2*	7.2*	7.2*	-	-	-	-	-	-	-	-	-	-	-	-	-	-	4.9	6.0*	6.0*	6.0*	3.9
	6	6.6*	6.6*	6.6*	6.6*	3.9	5.8*	5.8*	5.8*	-	-	-	-	-	-	-	-	-	-	2.8	4.9	4.5	5.0*	5.6
	4.5	7.1	8.6*	8.6*	8.6*	3.8	6.3*	6.2	6.3*	2.4	4.2	3.9	5.2*	-	-	-	-	-	2.2	3.8	3.5	4.7*	6.5	
	3	-	-	-	-	3.5	6.4	5.9	7.1*	2.3	4.1	3.8	5.5*	-	-	-	-	-	1.9	3.4	3.1	4.7*	6.9	
	1.5	-	-	-	-	3.3	6.1	5.6	7.7*	2.2	4.0	3.7	5.6*	-	-	-	-	-	1.8	3.3	3.0	4.6*	7.0	
	0	-	-	-	-	3.2	6.0	5.5	7.4*	2.2	3.9	3.6	5.4*	-	-	-	-	-	1.9	3.4	3.1	4.4*	6.8	
	-1.5	-	-	-	-	3.2	6.0	5.5	6.2*	2.2	3.9	3.6	4.3*	-	-	-	-	-	2.2	3.9	3.6	4.0*	6.2	
2P Boom: 4.92 m Arm: 2.4 m Radial blade front/ outrigger rear	7.5	6.2*	6.2*	6.2*	6.2*	3.9	5.1*	5.1*	5.1*	-	-	-	-	-	-	-	-	-	3.8	4.7*	4.7*	4.7*	4.6	
	6	5.2*	5.2*	5.2*	5.2*	4.0	5.4*	5.4*	5.4*	2.5	4.3	4.0	4.3*	-	-	-	-	-	2.4	4.0*	3.9	4.0*	6.1	
	4.5	6.2*	6.2*	6.2*	6.2*	3.8	5.9*	5.9*	5.9*	2.4	4.2	3.9	5.0*	-	-	-	-	-	1.9	3.4	3.1	3.8*	6.9	
	3	-	-	-	-	3.6	6.5	6.0	6.8*	2.3	4.1	3.8	5.3*	-	-	-	-	-	1.7	3.0	2.8	3.8*	7.3	
	1.5	-	-	-	-	3.3	6.1	5.7	7.6*	2.2	4.0	3.7	5.6*	-	-	-	-	-	1.6	2.9	2.7	4.0*	7.4	
	0	5.1*	5.1*	5.1*	5.1*	3.2	6.0	5.5	7.5*	2.1	3.9	3.6	5.5*	-	-	-	-	-	1.7	3.0	2.8	4.2*	7.2	
	-1.5	5.7	8.9*	8.9*	8.9*	3.1	6.0	5.5	6.6*	2.1	3.9	3.6	4.7*	-	-	-	-	-	1.9	3.4	3.2	3.9*	6.6	
2P Boom: 4.92 m Arm: 2.6 m Radial blade front/ outrigger rear	9	-	-	-	-	-	-	-	-	-	-	-	-	-	-	-	-	-	7.7*	7.7*	7.7*	7.7*	1.7	
	7.5	5.7*	5.7*	5.7*	5.7*	4.0	5.2*	5.2*	5.2*	-	-	-	-	-	-	-	-	-	3.4	4.3*	4.3*	4.3*	4.9	
	6	4.7*	4.7*	4.7*	4.7*	4.0	5.2*	5.2*	5.2*	2.5	4.3	4.0	4.6*	-	-	-	-	-	2.3	3.7*	3.7*	3.7*	6.3	
	4.5	5.3*	5.3*	5.3*	5.3*	3.9	5.7*	5.7*	5.7*	2.5	4.2	3.9	4.9*	-	-	-	-	-	1.8	3.2	3.0	3.5*	7.1	
	3	-	-	-	-	3.6	6.5	6.0	6.7*	2.3	4.1	3.8	5.2*	1.6	2.9	2.7	3.6*	1.6	2.9	2.7	3.5*	7.5		
	1.5	-	-	-	-	3.3	6.2	5.7	7.5*	2.2	4.0	3.7	5.5*	1.6	2.9	2.7	4.3*	1.6	2.8	2.6	3.7*	7.6		
	0	5.3*	5.3*	5.3*	5.3*	3.2	6.0	5.5	7.6*	2.1	3.9	3.6	5.5*	-	-	-	-	-	1.6	2.9	2.7	4.1	7.4	
-1.5	5.7	9.4*	9.4*	9.4*	3.1	5.9	5.4	6.8*	2.1	3.9	3.6	4.9*	-	-	-	-	-	1.8	3.2	3.0	3.8*	6.8		

LIFTING CAPACITY EWR150F - Bolted undercarriage

At the arm end, without bucket and quick fit. Unit: 1 000 kg.

For lifting capacity including bucket/quick fit, simply subtract actual weight of those parts from the following values.

	Lifting point	Reach from machine centre (u = support up/d = support down)																					
		3.0 m					4.5 m					6.0 m				7.0 m				Max.			
		Across UC		Along UC			Across UC		Along UC			Across UC		Along UC		Across UC		Along UC		Across UC		Along UC	Max.
		m	u	d	u	d	u	d	u	d	u	d	u	d	u	d	u	d	u	d	u	d	m
2P Boom: 4.92 m Arm: 2.0 m Parallel blade front/ outrigger rear	7.5	7.2*	7.2*	7.2*	7.2*	-	-	-	-	-	-	-	-	-	-	-	-	-	4.9	6.0*	6.0*	6.0*	3.9
	6	6.6*	6.6*	6.6*	6.6*	3.9	5.8*	5.8*	5.8*	-	-	-	-	-	-	-	-	-	2.8	4.9	4.5	5.0*	5.6
	4.5	7.1	8.6*	8.6*	8.6*	3.8	6.3*	6.2	6.3*	2.4	4.2	3.9	5.2*	-	-	-	-	-	2.2	3.8	3.5	4.7*	6.5
	3	-	-	-	-	3.5	6.4	5.9	7.1*	2.3	4.1	3.8	5.5*	-	-	-	-	-	1.9	3.4	3.1	4.7*	6.9
	1.5	-	-	-	-	3.3	6.1	5.6	7.7*	2.2	4.0	3.7	5.6*	-	-	-	-	-	1.8	3.3	3.0	4.6*	7.0
	0	-	-	-	-	3.2	6.0	5.5	7.4*	2.2	3.9	3.6	5.4*	-	-	-	-	-	1.9	3.4	3.1	4.4*	6.8
	-1.5	-	-	-	-	3.2	6.0	5.5	6.2*	2.2	3.9	3.6	4.3*	-	-	-	-	-	2.2	3.9	3.6	4.0*	6.2
2P Boom: 4.92 m Arm: 2.4 m Parallel blade front/ outrigger rear	7.5	6.2*	6.2*	6.2*	6.2*	3.9	5.1*	5.1*	5.1*	-	-	-	-	-	-	-	-	-	3.8	4.7*	4.7*	4.7*	4.6
	6	5.2*	5.2*	5.2*	5.2*	4.0	5.4*	5.4*	5.4*	2.5	4.3	4.0	4.3*	-	-	-	-	-	2.4	4.0*	3.9	4.0*	6.1
	4.5	6.2*	6.2*	6.2*	6.2*	3.8	5.9*	5.9*	5.9*	2.4	4.2	3.9	5.0*	-	-	-	-	-	1.9	3.4	3.1	3.8*	6.9
	3	-	-	-	-	3.6	6.5	6.0	6.8*	2.3	4.1	3.8	5.3*	-	-	-	-	-	1.7	3.0	2.8	3.8*	7.3
	1.5	-	-	-	-	3.3	6.1	5.7	7.6*	2.2	4.0	3.7	5.6*	-	-	-	-	-	1.6	2.9	2.7	4.0*	7.4
	0	5.1*	5.1*	5.1*	5.1*	3.2	6.0	5.5	7.5*	2.1	3.9	3.6	5.5*	-	-	-	-	-	1.7	3.0	2.8	4.2*	7.2
	-1.5	5.7	8.9*	8.9*	8.9*	3.1	6.0	5.5	6.6*	2.1	3.9	3.6	4.7*	-	-	-	-	-	1.9	3.4	3.2	3.9*	6.6
2P Boom: 4.92 m Arm: 2.6 m Parallel blade front/ outrigger rear	9	-	-	-	-	-	-	-	-	-	-	-	-	-	-	-	-	-	7.7*	7.7*	7.7*	7.7*	1.7
	7.5	5.7*	5.7*	5.7*	5.7*	4.0	5.2*	5.2*	5.2*	-	-	-	-	-	-	-	-	-	3.4	4.3*	4.3*	4.3*	4.9
	6	4.7*	4.7*	4.7*	4.7*	4.0	5.2*	5.2*	5.2*	2.5	4.3	4.0	4.6*	-	-	-	-	-	2.3	3.7*	3.7*	3.7*	6.3
	4.5	5.3*	5.3*	5.3*	5.3*	3.9	5.7*	5.7*	5.7*	2.5	4.2	3.9	4.9*	-	-	-	-	-	1.8	3.2	3.0	3.5*	7.1
	3	-	-	-	-	3.6	6.5	6.0	6.7*	2.3	4.1	3.8	5.2*	1.6	2.9	2.7	3.6*	1.6	2.9	2.7	3.5*	7.5	
	1.5	-	-	-	-	3.3	6.2	5.7	7.5*	2.2	4.0	3.7	5.5*	1.6	2.9	2.7	4.3*	1.6	2.8	2.6	3.7*	7.6	
	0	5.3*	5.3*	5.3*	5.3*	3.2	6.0	5.5	7.6*	2.1	3.9	3.6	5.5*	-	-	-	-	-	1.6	2.9	2.7	4.1	7.4
-1.5	5.7	9.4*	9.4*	9.4*	3.1	5.9	5.4	6.8*	2.1	3.9	3.6	4.9*	-	-	-	-	-	1.8	3.2	3.0	3.8*	6.8	

Specifications

LIFTING CAPACITY EWR150F - Bolted undercarriage

At the arm end, without bucket and quick fit. Unit: 1 000 kg.

For lifting capacity including bucket/quick fit, simply subtract actual weight of those parts from the following values.

	Lifting point	Reach from machine centre (u = support up/d = support down)																						
		3.0 m					4.5 m					6.0 m				7.0 m				Max.				
		Across UC		Along UC			Across UC		Along UC			Across UC		Along UC		Across UC		Along UC		Across UC		Along UC	Max.	
m	u	d	u	d	u	d	u	d	u	d	u	d	u	d	u	d	u	d	u	d	m			
2P Boom: 4.92 m Arm: 2.0 m Outrigger front/ Parallel blade rear	7.5	7.2*	7.2*	7.2*	7.2*	-	-	-	-	-	-	-	-	-	-	-	-	-	-	4.9	6.0*	6.0*	3.9	
	6	6.6*	6.6*	6.6*	6.6*	4.0	5.8*	5.8*	5.8*	-	-	-	-	-	-	-	-	-	-	2.8	4.7	4.3	5.0*	5.6
	4.5	7.2	8.6*	8.6*	8.6*	3.9	6.3*	6.0	6.3*	2.5	4.2	3.8	5.2*	-	-	-	-	-	-	2.2	3.7	3.3	4.7*	6.5
	3	-	-	-	-	3.6	6.4	5.7	7.1*	2.4	4.1	3.7	5.5*	-	-	-	-	-	-	1.9	3.3	3.0	4.7*	6.9
	1.5	-	-	-	-	3.4	6.1	5.5	7.7*	2.3	4.0	3.6	5.6*	-	-	-	-	-	-	1.8	3.2	2.8	4.6*	7.0
	0	-	-	-	-	3.3	6.0	5.3	7.4*	2.2	3.9	3.5	5.4*	-	-	-	-	-	-	1.9	3.3	3.0	4.4*	6.8
-1.5	-	-	-	-	3.3	6.0	5.4	6.2*	2.3	3.9	3.5	4.3*	-	-	-	-	-	-	2.2	3.8	3.4	4.0*	6.2	
2P Boom: 4.92 m Arm: 2.4 m Outrigger front/ Parallel blade rear	7.5	6.2*	6.2*	6.2*	6.2*	4.0	5.1*	5.1*	5.1*	-	-	-	-	-	-	-	-	-	-	3.9	4.7*	4.7*	4.7*	4.6
	6	5.2*	5.2*	5.2*	5.2*	4.1	5.4*	5.4*	5.4*	2.5	4.2	3.8	4.3*	-	-	-	-	-	-	2.5	4.0*	3.8	4.0*	6.1
	4.5	6.2*	6.2*	6.2*	6.2*	3.9	5.9*	5.9*	5.9*	2.5	4.2	3.8	5.0*	-	-	-	-	-	-	2.0	3.4	3.0	3.8*	6.9
	3	-	-	-	-	3.7	6.4	5.8	6.8*	2.4	4.1	3.7	5.3*	-	-	-	-	-	-	1.8	3.0	2.7	3.8*	7.3
	1.5	-	-	-	-	3.4	6.1	5.5	7.6*	2.3	4.0	3.6	5.6*	-	-	-	-	-	-	1.7	2.9	2.6	4.0*	7.4
	0	5.1*	5.1*	5.1*	5.1*	3.3	5.9	5.3	7.5*	2.2	3.9	3.5	5.5*	-	-	-	-	-	-	1.7	3.0	2.7	4.2*	7.2
-1.5	5.9	8.9*	8.9*	8.9*	3.2	5.9	5.3	6.6*	2.2	3.9	3.5	4.7*	-	-	-	-	-	-	2.0	3.4	3.1	3.9*	6.6	
2P Boom: 4.92 m Arm: 2.6 m Outrigger front/ Parallel blade rear	9	-	-	-	-	-	-	-	-	-	-	-	-	-	-	-	-	-	-	7.7*	7.7*	7.7*	7.7*	1.7
	7.5	5.7*	5.7*	5.7*	5.7*	4.1	5.2*	5.2*	5.2*	-	-	-	-	-	-	-	-	-	-	3.5	4.3*	4.3*	4.3*	4.9
	6	4.7*	4.7*	4.7*	4.7*	4.1	5.2*	5.2*	5.2*	2.6	4.3	3.9	4.6*	-	-	-	-	-	-	2.3	3.7*	3.6	3.7*	6.3
	4.5	5.3*	5.3*	5.3*	5.3*	4.0	5.7*	5.7*	5.7*	2.5	4.2	3.8	4.9*	-	-	-	-	-	-	1.9	3.2	2.9	3.5*	7.1
	3	-	-	-	-	3.7	6.4	5.8	6.7*	2.4	4.1	3.7	5.2*	1.7	2.9	2.6	3.6*	1.7	2.9	2.6	2.9	2.6	3.5*	7.5
	1.5	-	-	-	-	3.4	6.1	5.5	7.5*	2.3	4.0	3.6	5.5*	1.7	2.9	2.6	4.3*	1.6	2.8	2.5	3.7*	2.5	3.7*	7.6
0	5.3*	5.3*	5.3*	5.3*	3.3	5.9	5.3	7.6*	2.2	3.9	3.5	5.5*	-	-	-	-	-	-	1.7	2.9	2.6	4.1	7.4	
-1.5	5.8	9.4*	9.4*	9.4*	3.2	5.9	5.3	6.8*	2.2	3.9	3.5	4.9*	-	-	-	-	-	-	1.9	3.2	2.9	3.8*	6.8	

LIFTING CAPACITY EWR150F - Bolted undercarriage

At the arm end, without bucket and quick fit. Unit: 1 000 kg.

For lifting capacity including bucket/quick fit, simply subtract actual weight of those parts from the following values.

	Lifting point	Reach from machine centre (u = support up/d = support down)																						
		3.0 m					4.5 m					6.0 m				7.0 m				Max.				
		Across UC		Along UC			Across UC		Along UC			Across UC		Along UC		Across UC		Along UC		Across UC		Along UC	Max.	
m	u	d	u	d	u	d	u	d	u	d	u	d	u	d	u	d	u	d	u	d	m			
2P Boom: 4.92 m Arm: 2.0 m Outrigger front/ outrigger rear	7.5	7.2*	7.2*	7.2*	7.2*	-	-	-	-	-	-	-	-	-	-	-	-	-	-	5.0	6.0*	6.0*	6.0*	3.9
	6	6.6*	6.6*	6.6*	6.6*	4.1	5.8*	5.8*	5.8*	-	-	-	-	-	-	-	-	-	-	2.9	5.0*	4.4	5.0*	5.6
	4.5	7.3	8.6*	8.6*	8.6*	3.9	6.3*	6.2	6.3*	2.5	5.2*	3.9	5.2*	-	-	-	-	-	-	2.2	4.7*	3.4	4.7*	6.5
	3	-	-	-	-	3.7	7.1*	5.9	7.1*	2.4	5.3	3.8	5.5*	-	-	-	-	-	-	1.9	4.2	3.0	4.7*	6.9
	1.5	-	-	-	-	3.4	7.7*	5.6	7.7*	2.3	5.2	3.7	5.6*	-	-	-	-	-	-	1.9	4.1	2.9	4.6*	7.0
	0	-	-	-	-	3.3	7.4*	5.5	7.4*	2.3	5.1	3.6	5.4*	-	-	-	-	-	-	1.9	4.3	3.0	4.4*	6.8
-1.5	-	-	-	-	3.3	6.2*	5.5	6.2*	2.3	4.3*	3.6	4.3*	-	-	-	-	-	-	2.2	4.0*	3.5	4.0*	6.2	
2P Boom: 4.92 m Arm: 2.4 m Outrigger front/ outrigger rear	7.5	6.2*	6.2*	6.2*	6.2*	4.1	5.1*	5.1*	5.1*	-	-	-	-	-	-	-	-	-	-	3.9	4.7*	4.7*	4.7*	4.6
	6	5.2*	5.2*	5.2*	5.2*	4.1	5.4*	5.4*	5.4*	2.6	4.3*	3.9	4.3*	-	-	-	-	-	-	2.5	4.0*	3.9	4.0*	6.1
	4.5	6.2*	6.2*	6.2*	6.2*	4.0	5.9*	5.9*	5.9*	2.6	5.0*	3.9	5.0*	-	-	-	-	-	-	2.0	3.8*	3.1	3.8*	6.9
	3	-	-	-	-	3.7	6.8*	5.9	6.8*	2.4	5.3*	3.8	5.3*	-	-	-	-	-	-	1.8	3.8*	2.8	3.8*	7.3
	1.5	-	-	-	-	3.5	7.6*	5.6	7.6*	2.3	5.2	3.7	5.6*	-	-	-	-	-	-	1.7	3.8	2.7	4.0*	7.4
	0	5.1*	5.1*	5.1*	5.1*	3.3	7.5*	5.5	7.5*	2.3	5.1	3.6	5.5*	-	-	-	-	-	-	1.8	3.9	2.8	4.2*	7.2
-1.5	6.0	8.9*	8.9*	8.9*	3.3	6.6*	5.4	6.6*	2.2	4.7*	3.6	4.7*	-	-	-	-	-	-	2.0	3.9*	3.1	3.9*	6.6	
2P Boom: 4.92 m Arm: 2.6 m Outrigger front/ outrigger rear	9	-	-	-	-	-	-	-	-	-	-	-	-	-	-	-	-	-	-	7.7*	7.7*	7.7*	7.7*	1.7
	7.5	5.7*	5.7*	5.7*	5.7*	4.1	5.2*	5.2*	5.2*	-	-	-	-	-	-	-	-	-	-	3.6	4.3*	4.3*	4.3*	4.9
	6	4.7*	4.7*	4.7*	4.7*	4.2	5.2*	5.2*	5.2*	2.6	4.6*	4.0	4.6*	-	-	-	-	-	-	2.4	3.7*	3.7	3.7*	6.3
	4.5	5.3*	5.3*	5.3*	5.3*	4.0	5.7*	5.7*	5.7*	2.6	4.9*	3.9	4.9*	-	-	-	-	-	-	1.9	3.5*	3.0	3.5*	7.1
	3	-	-	-	-	3.7	6.7*	6.0	6.7*	2.5	5.2*	3.8	5.2*	1.7	3.6*	2.7	3.6*	1.7	3.5*	2.7	3.5*	2.7	3.5*	7.5
	1.5	-	-	-	-	3.5	7.5*	5.6	7.5*	2.3	5.2*	3.7	5.5*	1.7	3.7	2.6	4.3*	1.6	3.6	2.6	3.7*	2.6	3.7*	7.6
0	5.3*	5.3*	5.3*	5.3*	3.3	7.6*	5.5	7.6*	2.2	5.1*	3.6	5.5*	-	-	-	-	-	-	1.7	3.8	2.7	4.1	7.4	
-1.5	5.9	9.4*	9.4*	9.4*	3.3	6.8*	5.4	6.8*	2.2	4.9*	3.6	4.9*	-	-	-	-	-	-	1.9	3.8*	3.0	3.8*	6.8	

LIFTING CAPACITY EWR150F - Bolted undercarriage

At the arm end, without bucket and quick fit. Unit: 1 000 kg.

For lifting capacity including bucket/quick fit, simply subtract actual weight of those parts from the following values.

	Lifting point	Reach from machine centre (u = support up/d = support down)																							
		3.0 m				4.5 m				6.0 m				7.0 m				Max.							
		Across UC		Along UC		Across UC		Along UC		Across UC		Along UC		Across UC		Along UC		Across UC		Along UC		Max.			
		m	u	d	u	d	u	d	u	d	u	d	u	d	u	d	u	d	u	d	u	d	m		
2P Boom: 4.92 m Arm: 2.0 m Parallel blade rear	7.5	7.2*	7.2*	7.2*	7.2*	-	-	-	-	-	-	-	-	-	-	-	-	-	-	-	4.7	5.3	6.0*	6.0*	3.9
	6	6.6*	6.6*	6.6*	6.6*	3.8	4.3	5.8*	5.8*	-	-	-	-	-	-	-	-	-	-	-	2.6	3.0	4.4	5.0*	5.6
	4.5	6.9	8.0	8.6*	8.6*	3.7	4.2	6.2	6.3*	2.3	2.7	3.9	5.2*	-	-	-	-	-	-	-	2.0	2.3	3.5	4.7*	6.5
	3	-	-	-	-	3.4	3.9	5.9	7.1*	2.2	2.6	3.8	5.5*	-	-	-	-	-	-	-	1.8	2.1	3.1	4.7*	6.9
	1.5	-	-	-	-	3.2	3.7	5.7	7.7*	2.1	2.5	3.7	5.6*	-	-	-	-	-	-	-	1.7	2.0	3.0	4.6	7.0
	0	-	-	-	-	3.1	3.6	5.6	7.4*	2.1	2.4	3.7	5.4*	-	-	-	-	-	-	-	1.8	2.0	3.1	4.4*	6.8
	-1.5	-	-	-	-	3.1	3.6	5.6	6.2*	2.1	2.4	3.7	4.3*	-	-	-	-	-	-	-	2.0	2.3	3.5	4.0*	6.2
2P Boom: 4.92 m Arm: 2.4 m Parallel blade rear	7.5	6.2*	6.2*	6.2*	6.2*	3.8	4.3	5.1*	5.1*	-	-	-	-	-	-	-	-	-	-	-	3.7	4.2	4.7*	4.7*	4.6
	6	5.2*	5.2*	5.2*	5.2*	3.9	4.4	5.4*	5.4*	2.4	2.7	4.0	4.3*	-	-	-	-	-	-	-	2.3	2.7	3.9	4.0*	6.1
	4.5	6.2*	6.2*	6.2*	6.2*	3.7	4.2	5.9*	5.9*	2.4	2.7	4.0	5.0*	-	-	-	-	-	-	-	1.9	2.1	3.2	3.8*	6.9
	3	-	-	-	-	3.4	4.0	6.0	6.8*	2.3	2.6	3.9	5.3*	-	-	-	-	-	-	-	1.6	1.9	2.8	3.8*	7.3
	1.5	-	-	-	-	3.2	3.7	5.7	7.6*	2.1	2.5	3.7	5.6*	-	-	-	-	-	-	-	1.6	1.8	2.7	4.0*	7.4
	0	5.1*	5.1*	5.1*	5.1*	3.0	3.5	5.5	7.5*	2.1	2.4	3.6	5.5*	-	-	-	-	-	-	-	1.6	1.9	2.8	4.2*	7.2
	-1.5	5.5	6.5	8.9*	8.9*	3.0	3.5	5.5	6.6*	2.1	2.4	3.6	4.7*	-	-	-	-	-	-	-	1.8	2.1	3.2	3.9*	6.6
2P Boom: 4.92 m Arm: 2.6 m Parallel blade rear	9	-	-	-	-	-	-	-	-	-	-	-	-	-	-	-	-	-	-	-	7.7*	7.7*	7.7*	7.7*	1.7
	7.5	5.7*	5.7*	5.7*	5.7*	3.8	4.4	5.2*	5.2*	-	-	-	-	-	-	-	-	-	-	-	3.3	3.8	4.3*	4.3*	4.9
	6	4.7*	4.7*	4.7*	4.7*	3.9	4.4	5.2*	5.2*	2.4	2.7	4.0	4.6*	-	-	-	-	-	-	-	2.2	2.5	3.7*	3.7*	6.3
	4.5	5.3*	5.3*	5.3*	5.3*	3.7	4.3	5.7*	5.7*	2.4	2.7	4.0	4.9*	-	-	-	-	-	-	-	1.8	2.0	3.0	3.5*	7.1
	3	-	-	-	-	3.5	4.0	6.0	6.7*	2.3	2.6	3.9	5.2*	1.6	1.8	2.7	3.6*	1.6	1.8	2.7	3.5*	3.5*	7.5		
	1.5	-	-	-	-	3.2	3.7	5.7	7.5*	2.1	2.5	3.7	5.5*	1.5	1.8	2.7	4.1	1.5	1.7	2.6	3.7*	3.7*	7.6		
	0	5.3*	5.3*	5.3*	5.3*	3.0	3.5	5.5	7.6*	2.1	2.4	3.6	5.5*	-	-	-	-	-	-	-	1.5	1.8	2.7	4.1	7.4
-1.5	5.5	6.5	9.4*	9.4*	3.0	3.5	5.5	6.8*	2.0	2.4	3.6	4.9*	-	-	-	-	-	-	-	1.7	2.0	3.0	3.8*	6.8	

LIFTING CAPACITY EWR150F - Bolted undercarriage

At the arm end, without bucket and quick fit. Unit: 1 000 kg.

For lifting capacity including bucket/quick fit, simply subtract actual weight of those parts from the following values.

	Lifting point	Reach from machine centre (u = support up/d = support down)																							
		3.0 m				4.5 m				6.0 m				7.0 m				Max.							
		Across UC		Along UC		Across UC		Along UC		Across UC		Along UC		Across UC		Along UC		Across UC		Along UC		Max.			
		m	u	d	u	d	u	d	u	d	u	d	u	d	u	d	u	d	u	d	u	d	m		
2P Boom: 4.92 m Arm: 2.0 m Parallel blade front / Parallel blade rear	7.5	7.2*	7.2*	7.2*	7.2*	-	-	-	-	-	-	-	-	-	-	-	-	-	-	-	4.9	6.0*	6.0*	6.0*	3.9
	6	6.6*	6.6*	6.6*	6.6*	4.0	5.4	5.8*	5.8*	-	-	-	-	-	-	-	-	-	-	-	2.8	3.8	4.3	5.0*	5.6
	4.5	7.2	8.6	8.6*	8.6*	3.8	5.3	6.1	6.3*	2.5	3.4	3.8	5.2*	-	-	-	-	-	-	-	2.2	3.0	3.4	4.7*	6.5
	3	-	-	-	-	3.6	5.0	5.8	7.1*	2.4	3.3	3.7	5.5*	-	-	-	-	-	-	-	1.9	2.6	3.0	4.7*	6.9
	1.5	-	-	-	-	3.3	4.7	5.5	7.7*	2.3	3.2	3.6	5.6*	-	-	-	-	-	-	-	1.8	2.5	2.9	4.6*	7.0
	0	-	-	-	-	3.2	4.6	5.4	7.4*	2.2	3.1	3.6	5.4*	-	-	-	-	-	-	-	1.9	2.6	3.0	4.4*	6.8
	-1.5	-	-	-	-	3.2	4.6	5.4	6.2*	2.2	3.1	3.6	4.3*	-	-	-	-	-	-	-	2.2	3.0	3.5	4.0*	6.2
2P Boom: 4.92 m Arm: 2.4 m Parallel blade front / Parallel blade rear	7.5	6.2*	6.2*	6.2*	6.2*	4.0	5.1*	5.1*	5.1*	-	-	-	-	-	-	-	-	-	-	-	3.8	4.7*	4.7*	4.7*	4.6
	6	5.2*	5.2*	5.2*	5.2*	4.0	5.4*	5.4*	5.4*	2.5	3.4	3.9	4.3*	-	-	-	-	-	-	-	2.5	3.4	3.8	4.0*	6.1
	4.5	6.2*	6.2*	6.2*	6.2*	3.9	5.3	5.9*	5.9*	2.5	3.4	3.9	5.0*	-	-	-	-	-	-	-	2.	2.7	3.1	3.8*	6.9
	3	-	-	-	-	3.6	5.1	5.9	6.8*	2.4	3.3	3.8	5.3*	-	-	-	-	-	-	-	1.7	2.4	2.8	3.8*	7.3
	1.5	-	-	-	-	3.4	4.8	5.6	7.6*	2.3	3.2	3.6	5.6*	-	-	-	-	-	-	-	1.7	2.3	2.7	4.0*	7.4
	0	5.1*	5.1*	5.1*	5.1*	3.2	4.6	5.4	7.5*	2.2	3.1	3.5	5.5*	-	-	-	-	-	-	-	1.7	2.4	2.7	4.2*	7.2
	-1.5	5.8	8.8	8.9*	8.9*	3.2	4.6	5.4	6.6*	2.2	3.1	3.5	4.7*	-	-	-	-	-	-	-	1.9	2.7	3.1	3.9*	6.6
2P Boom: 4.92 m Arm: 2.6 m Parallel blade front / Parallel blade rear	9	-	-	-	-	-	-	-	-	-	-	-	-	-	-	-	-	-	-	-	7.7*	7.7*	7.7*	7.7*	1.7
	7.5	5.7*	5.7*	5.7*	5.7*	4.0	5.2*	5.2*	5.2*	-	-	-	-	-	-	-	-	-	-	-	3.5	4.3*	4.3*	4.3*	4.9
	6	4.7*	4.7*	4.7*	4.7*	4.1	5.2*	5.2*	5.2*	2.5	3.4	3.9	4.6*	-	-	-	-	-	-	-	2.3	3.2	3.6	3.7*	6.3
	4.5	5.3*	5.3*	5.3*	5.3*	3.9	5.4	5.7*	5.7*	2.5	3.4	3.9	4.9*	-	-	-	-	-	-	-	1.9	2.6	2.9	3.5*	7.1
	3	-	-	-	-	3.6	5.1	5.9	6.7*	2.4	3.3	3.8	5.2*	1.7	2.3	2.6	3.6*	1.7	2.3	2.6	3.5*	3.5*	7.5		
	1.5	-	-	-	-	3.4	4.8	5.6	7.5*	2.3	3.2	3.6	5.5*	1.6	2.3	2.6	4.3*	1.6	2.2	2.6	3.7*	3.7*	7.6		
	0	5.3*	5.3*	5.3*	5.3*	3.2	4.6	5.4	7.6*	2.2	3.1	3.5	5.5*	-	-	-	-	-	-	-	1.6	2.3	2.6	4.1	7.4
-1.5	5.8	8.8	9.4*	9.4*	3.2	4.6	5.3	6.8*	2.2	3.0	3.5	4.9*	-	-	-	-	-	-	-	1.8	2.6	2.9	3.8*	6.8	

Equipment

STANDARD EQUIPMENT

Engine

Turbocharged, 4 stroke Volvo diesel engine with water cooling, direct injection and charged air cooler that meets EU Stage V emission requirements

Intake air pre-heater

Fuel filter and water separator

Fuel filler pump: 50 l/min with automatic shut-off

Aluminium core radiator

Electrical system

Contronics-computerized monitoring and diagnostic system

Master electrical disconnect switch

Adjustable automatic idling system

One-touch power boost

single 12.8" touch screen

Safety stop/start function

LED Headlights

Alternator, 130 A

Batteries, 2 x 12 V/100 Ah

Start motor, 24 V/5.5 kW

CareTrack via GSM or satellite

Rear and Side view camera

Superstructure

LED Rear lights

Service walkway with anti-slip grating

Centralised lubricating point for slew bearing and boom

Undercarriage and structures

3 speeds (creep / offroad / road speed up to 35 km/h)

Oscillating front axle $\pm 9^\circ$ without mudguards/ 6° with mudguards

2-circuit travel brakes

Maintenance-free propeller shafts

Hydraulic System

Load sensing hydraulic system

Cylinder cushioning

Cylinder contamination seals

Return filter of full flow type 3 000 h exchange interval

Pressure relief system (servo accumulator)

Proportional controlled visco-clutch cooling fan

Hose rupture valve for boom and arm

Hydraulic long life oil ISO VG 46

X1 Circuit (e.g. Hammer & shears)

STANDARD EQUIPMENT

Cab and interior

Volvo Care Cab with fixed roof hatch /ROPS

Door locks

Safety glass, light tinted

Floor mat

Horn

Large storage area

Pull-up type front window

Removable lower windshield

Retractable seat belt

Windshield wiper with washer and intermittent feature

Cooling box

Sun shield, front, roof & rear

DAB Radio

Bluetooth connection

2 USB ports

Engine Start/Stop Button

Heater & air-conditioner, automatic

Hydraulic dampening cab mounts

Adjustable operator seat and joystick control console

Adjustable steering column

Hydraulic safety lock lever

Control joysticks different variants

Digging equipment

Attachment points for extra hydraulics

Centralised lubrication point for arm and bucket

4,92 m 2-piece boom

Dipper arms : 2.0 m, 2.4 m, 2.6 m

Service

Tool kit, daily maintenance

Automatic Greasing System

Wheel chocks

Attachments

Buckets, direct fit and for Quick Couplers:

General Purpose bucket (GP)

GPX bucket

Lifting eye

Tilt rotator Steelwrist

OPTIONAL EQUIPMENT

Engine

Diesel coolant heater with digital timer
Block heater, 240 V
Water separator with heater
Dust net
Reversible fan
Air inlet turbo precleaning system
Tropical cooling

Electrical system

Travel alarm
Rotating beacon
Extra work lights: LED
2 additional lights on the boom
2 additional lights on the cabin front
1 additional light on the arm
1 additional light on the LH side
1 additional light cab rear
Welcome home light option
Multi-channel electric centre passage
Anti-theft system
Tilting and rotating attachment preparation

Undercarriage and structures

Twin tires 10.00 – 20 / 11.00 – 20
Single tires 18R – 19.5 / 620/40-22.5
Single tires 650/45-22.5
Stone protection rings
Solid rubber tires 10.00-20/11.00-20
parallel dozer blade and outriggers at rear and front
License plate preparation
Grab holder
Mudguards, front/rear, plastic or metal
Tool box, left hand side/right hand side
Cruise control
Travel speed 20 km/h, 30 km/h, 35 km/h
Trailer Towing system
Automatic digging brake
Drawer type Toolbox
4 Wheel Steering
Hydraulic trailer brake
Double Acting Hydraulic

OPTIONAL EQUIPMENT

Hydraulic System

Boom float function
Hydraulic oil, biodegradable ISO VG 32
Hydraulic oil, biodegradable ISO VG 46
Hydraulic long life oil ISO VG 32
Hydraulic long life oil ISO VG 68
X3 circuit (e.g. Slope bucket/rotator)
X4 circuit (aux functions)
Flow & pressure control for X1/X3/X4
Boom suspension system

Cab and interior

Volvo Care Cab with openable PC roof hatch / ROPS
A9 joystick
L8 joystick
L8 simple joystick
Proportional control joystick
Falling object guard (FOG)
Cab mounted falling object protective structures (FOPS)
Rain shield, front
Smart Connect MiC 4.0
Volvo Smart View system
Safety net for front window
Lower wiper
Seat:
Premium seat with airsuspension, 3 step heat/Vent, 2-point seatbelt
Deluxe seat with airsuspension, 3 step heat/Vent, X-Isolator & elect lumbar support, 2-point seatbelt
Premium seat ISRI with airsuspension, heat, 3-point seatbelt
Deluxe seat ISRI with airsuspension, 3 step heat/Vent, X-Isolator & elect lumbar support, automatic weight adjustment, 3-point seatbelt
Deluxe Armrest
Standard Armrest
Comfort Cabin Stairs

Hydraulic quick fit

Full hydraulic Quick coupler (SQ)
S60 system
Universal system

V O L V O